

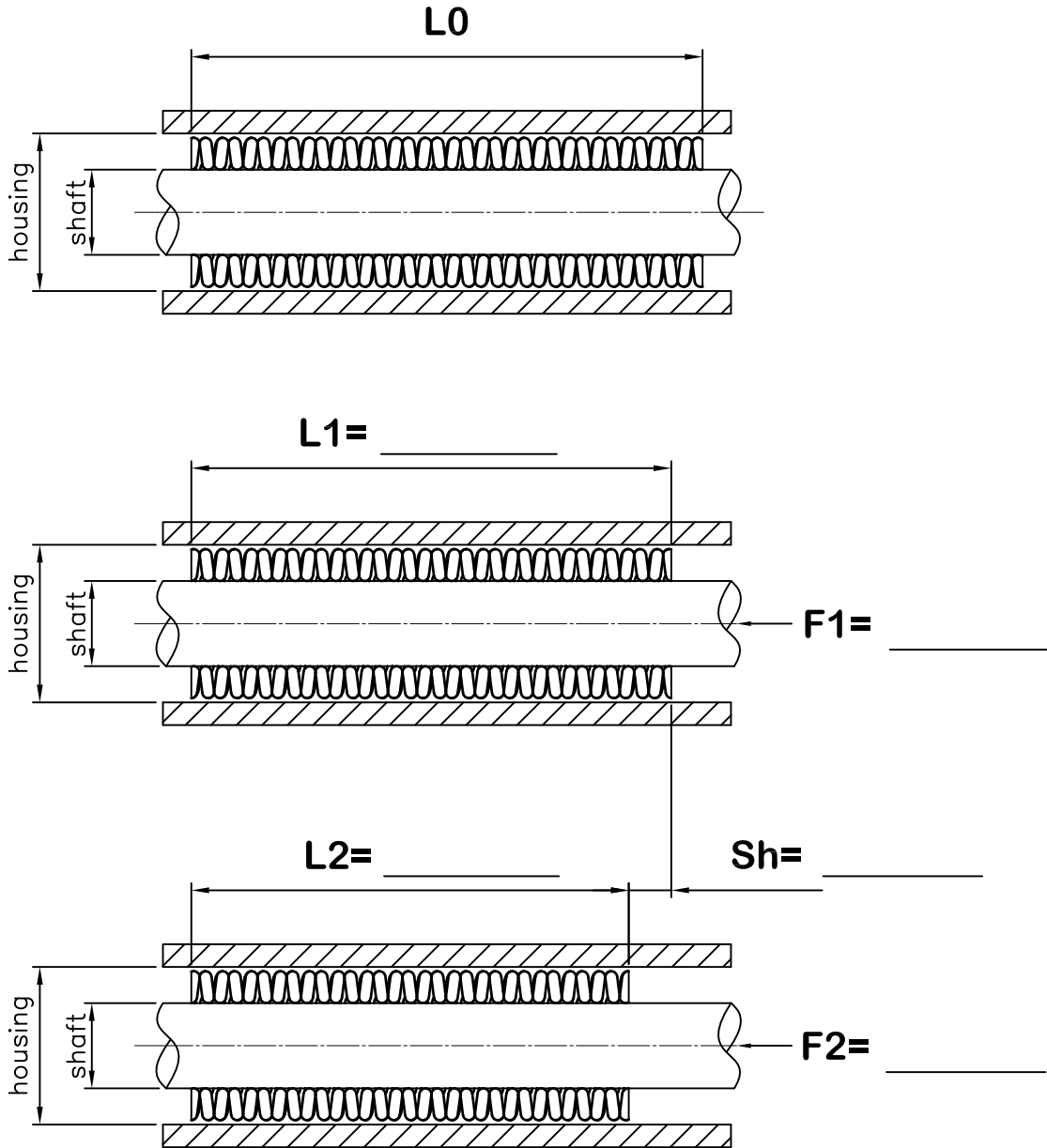

Inquiry-No. (需求编号)	Customer (客户名称)	City (所在城市)	MC-type (机器形式)	Spindle-type /Clamping (主轴/夹爪形式)
Incoming Date of Inquiry (访查日期)	Sales Company (销售公司)	Sales (销售人员)	Yield (产量)	Yield (产量)

◆ Single spring



Application:

T° = _____ °C shaft = _____ mm L0 = spring untense
n = _____ rpm housing = _____ mm L1 = tool tensely
L2 = tool stretched

DIN 7168(mm)		CONTACT	http://www.sefko.biz		
6 ±0.05		TITLE	SeFko Spring for milling machine		
6~30 ±0.07					
30~120 ±0.1		DWN.	REC.	APP.	
120~400 ±0.2		Amber			
400~1000 ±0.3		DWG NO.	FR-0000007	REV	1

